

SOFA

Milton

MODULAR SOFA



Modular sofa with structure in solid wood, plywood and polyurethane foam in various densities. Resinated and coupled with cotton. Seat cushions in polyurethane foam of various densities and feather mattress. Back cushions in down (67%) and ROLLOFILL (33%). Entirely removable in all its parts. Base frame in aluminum varnished in matte bronze nickel, matte champagne, or in glossy black nickel or glossy champagne galvanized. Foot insert in Vetricite.
Optional on the armrest: side storage pocket in leather.

Technical Features

Design Massimiliano Raggi

C12 MODULAR COMPOSITION

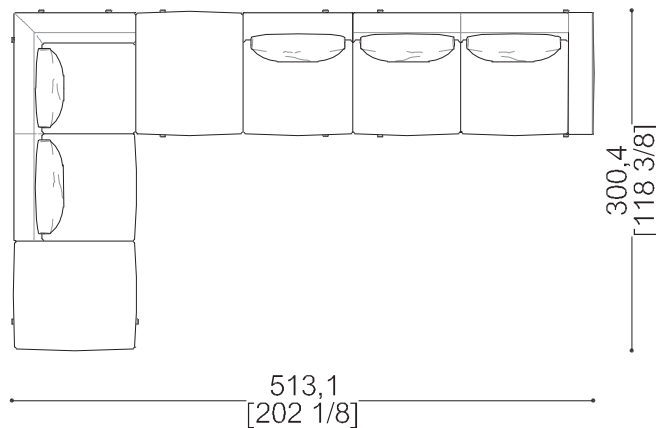

MIT04 SX / MIA02 DX / MIC02 SX / MIT05 DX

SOFA

Milton
MODULAR COMPOSITIONS

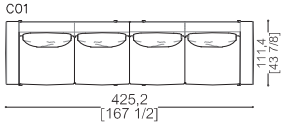

MIT04 SX / MIT04 DX

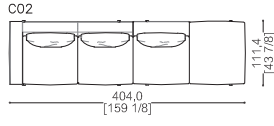

MIT04 SX / MIC01 DX

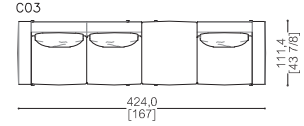

MIT04 SX / MIT03 DX

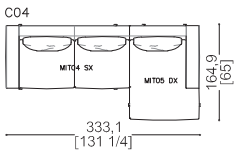

MIT04 SX / MIT05 DX

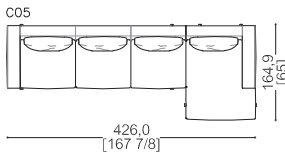

MIT02 SX / MIT05 DX

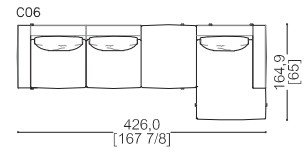

MIT01 SX / MIT05 DX

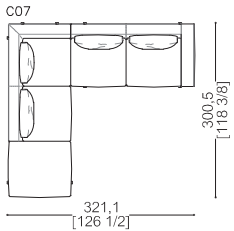

MIA01 SX / MIT04 DX

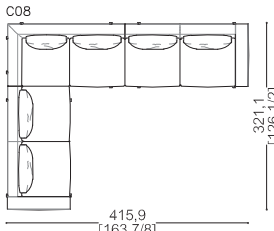

MIT04 SX /MIA02 DX / MIT04 DX

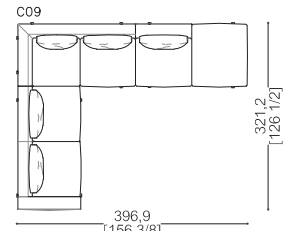

MIT04 SX /MIA02 DX / MIC01 DX

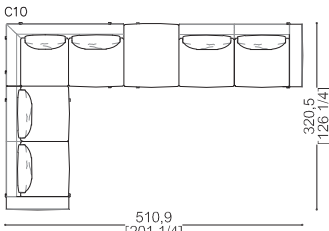

MIT04 SX /MIA02 DX / MIT04 DX

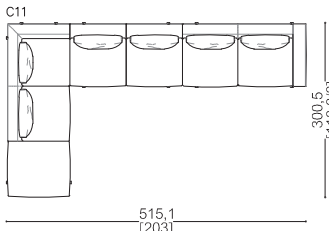

MIA01 SX /MIC02 SX / MIT04 DX

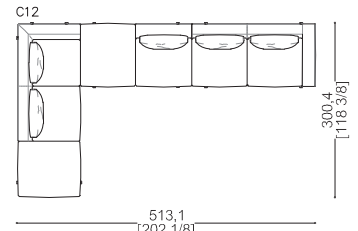

MIA01 SX /MIC02 SX / MIT04 DX

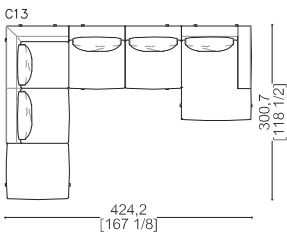

MIA01 SX /MIC02 SX / MIT05 DX

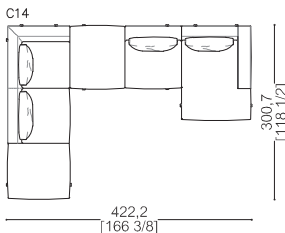

MIA01 SX /MIC01 SX / MIT05 DX

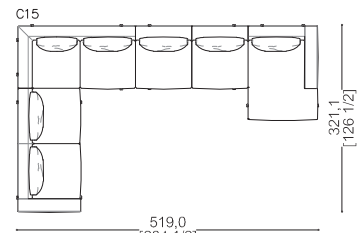

MIT04 SX /MIA02 DX / MIC02 SX / MIT05 DX

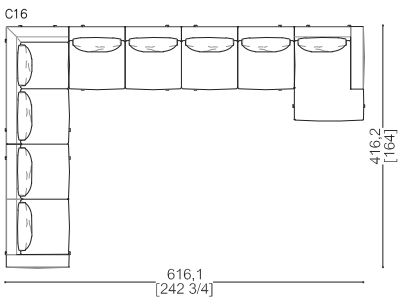

MIT04 SX / MIA02 SX / MIC02 SX / MIC02 SX / MIT05 DX

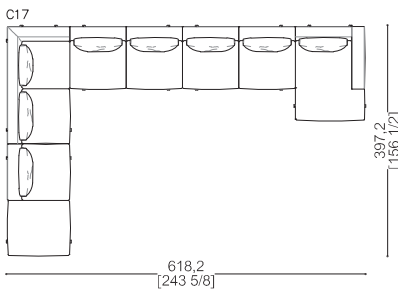

MIC01 SX / MIA02 SX / MIC02 SX / MIC01 SX / MIT05 DX

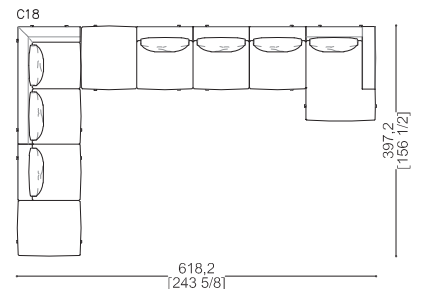

MIC01 SX / MIA02 SX / MIC01 SX / MIC02 SX / MIT05 DX

SOFA

Milton
MI01 3 SEATERS SOFA



Three seaters sofa with structure in solid wood, plywood and polyurethane foam in various densities. Resinated and coupled with cotton. Seat cushions in polyurethane foam of various densities and feather mattress. Back cushions in down (67%) and ROLLOFILL (33%). Entirely removable in all its parts. Base frame in aluminum varnished in matte bronze nickel, matte champagne, or in glossy black nickel or glossy champagne galvanized. Foot insert in Vetrice. Optional on the armrest: side storage pocket in leather.

Technical Features

Design Massimiliano Raggi

WEIGHT
130 KG

COM
19,3 ML

COL
27 SQM

PACKING
CARTON BOX + PALLET
W: 337 X D: 120 X H: 85 CM
W: 132 5/8" X D: 47 1/4" X H: 33 1/2"

GROSS WEIGHT
150 KG

VOLUME
3,5 CBM

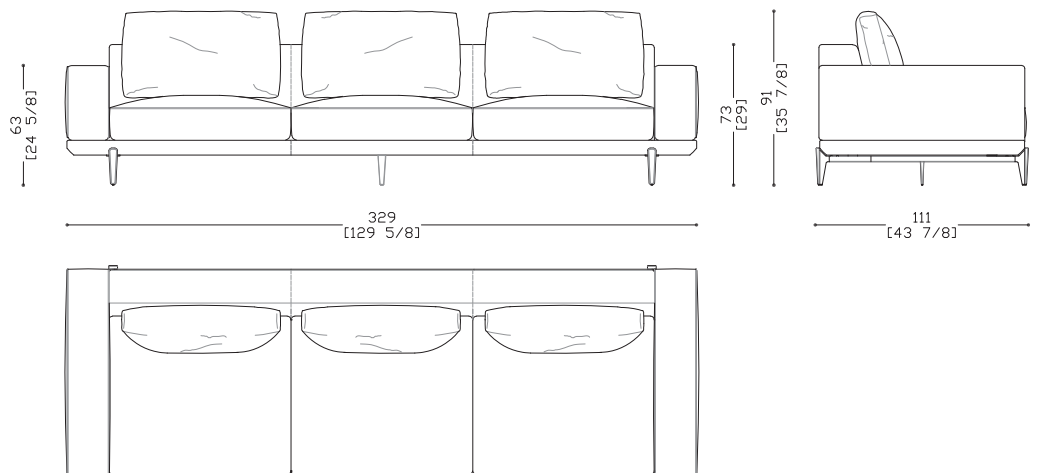

SOFA

Milton

MI02 2 SEATERS LARGE SOFA



Two seaters sofa with structure in solid wood, plywood and polyurethane foam in various densities. Resinated and coupled with cotton. Seat cushions in polyurethane foam of various densities and feather mattress. Back cushions in down (67%) and ROLLOFILL (33%). Entirely removable in all its parts. Base frame in aluminum varnished in matte bronze nickel, matte champagne, or in glossy black nickel or glossy champagne galvanized. Foot insert in Vetricite.
Optional on the armrest: side storage pocket in leather.

Technical Features

Design Massimiliano Raggi

WEIGHT
70 KG

COM
14 ML

COL
19,6 SQM

PACKING
CARTON BOX + PALLET
W: 272 X D: 120 X H: 85 CM
W: 107^{1/8"} X D: 47^{1/4"} X H: 33^{1/2"}

GROSS WEIGHT
150 KG

VOLUME
2,8 CBM

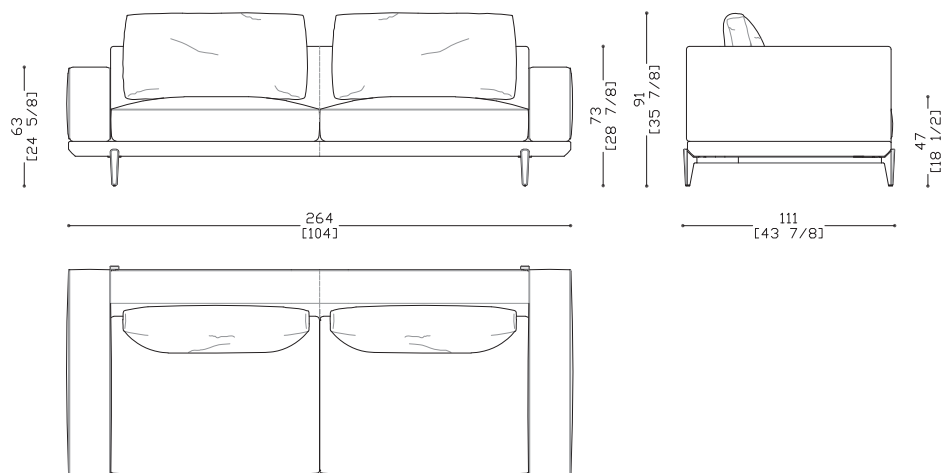

SOFA

Milton

MIA01 DX CORNER UNIT LARGE OTTOMAN



Corner unit large ottoman with structure in solid wood, plywood and polyurethane foam in various densities. Resinated and coupled with cotton. Seat cushions in polyurethane foam of various densities and feather mattress. Back cushions in down (67%) and ROLLOFILL (33%). Entirely removable in all its parts. Base frame in aluminum varnished in matte bronze nickel, matte champagne, or in glossy black nickel or glossy champagne galvanized. Foot insert in Vetrice.

Technical Features

Design Massimiliano Raggi

WEIGHT
120 KG

COM
15,5 ML

COL
21,7 SQM

PACKING
CARTON BOX + PALLET
W: 305 X D: 120 X H: 85 CM
W: 120^{1/8"} X D: 47^{1/8"} X H: 33^{1/2"}

GROSS WEIGHT
150 KG

VOLUME
3,1 CBM

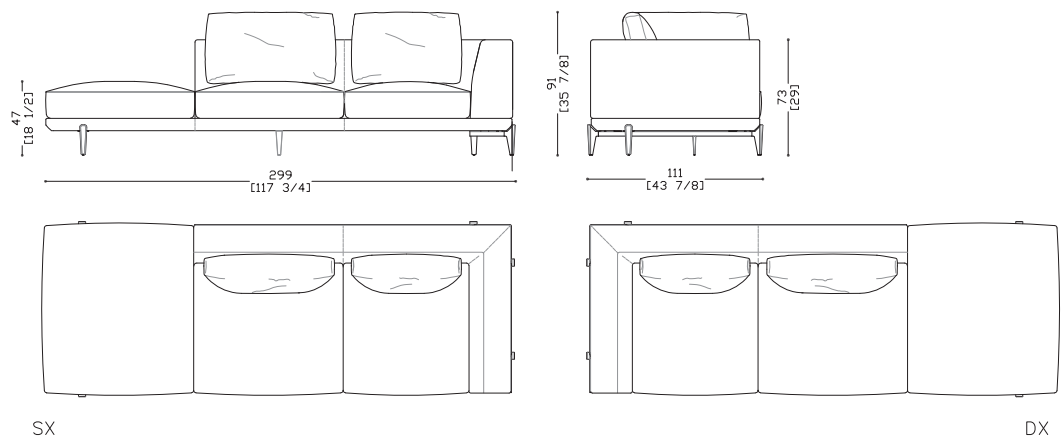

SOFA

Milton
MIA02 DX CORNER UNIT MIDDLE



Corner unit middle with structure in solid wood, plywood and polyurethane foam in various densities. Resinated and coupled with cotton. Seat cushions in polyurethane foam of various densities and feather mattress. Back cushions in down (67%) and ROLLOFILL (33%). Entirely removable in all its parts. Base frame in aluminum varnished in matte bronze nickel, matte champagne, or in glossy black nickel or glossy champagne galvanized. Foot insert in Vetrite.

Technical Features

Design Massimiliano Raggi

WEIGHT
75 KG

COM
12,5 ML

COL
17,6 SQM

PACKING
CARTON BOX + PALLET
W: 215 X D: 120 X H: 85 CM
W: 84 ^{5/8"} X D: 47 ^{1/4"} X H: 33 ^{1/2"}

GROSS WEIGHT
100 KG

VOLUME
2,2 CBM

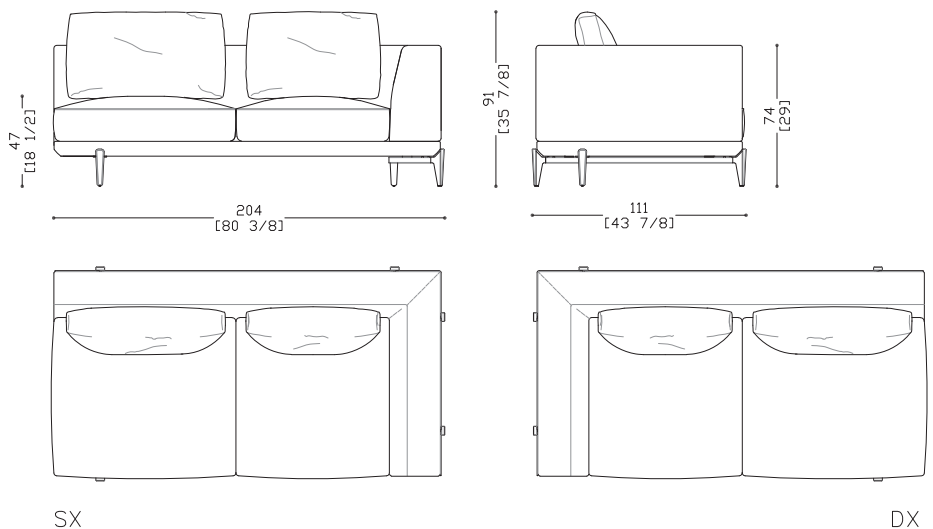

SOFA

Milton

MIA03 DX CORNER UNIT MIDDLE OTTOMAN



Corner unit middle ottoman with structure in solid wood, plywood and polyurethane foam in various densities. Resinated and coupled with cotton. Seat cushions in polyurethane foam of various densities and feather mattress. Back cushions in down (67%) and ROLLOFILL (33%). Entirely removable in all its parts. Base frame in aluminum varnished in matte bronze nickel, matte champagne, or in glossy black nickel or glossy champagne galvanized. Foot insert in Vetrite.

Technical Features

Design Massimiliano Raggi

WEIGHT
70 KG

COM
11,6 ML

COL
16,2 SQM

PACKING
CARTON BOX + PALLET
W: 215 X D: 120 X H: 85 CM
W: 84 ^{5/8}" X D: 47 ^{1/4}" X H: 33 ^{1/2}"

GROSS WEIGHT
95 KG

VOLUME
2,2 CBM

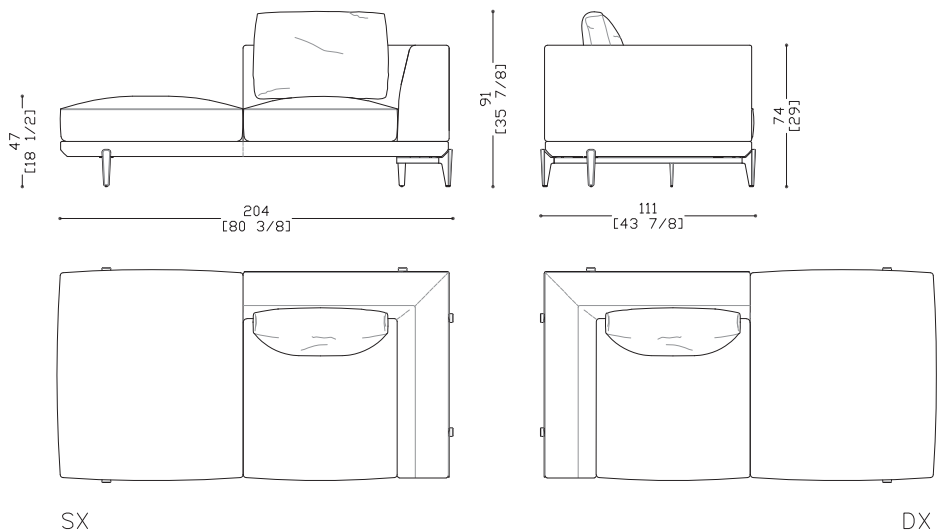

SOFA

Milton
MIC01 SX MIDDLE UNIT OTTOMAN



Middle unit ottoman with structure in solid wood, plywood and polyurethane foam in various densities. Resinated and coupled with cotton. Seat cushions in polyurethane foam of various densities and feather mattress. Back cushions in down (67%) and ROLLOFILL (33%). Entirely removable in all its parts. Base frame in aluminum varnished in matte bronze nickel, matte champagne, or in glossy black nickel or glossy champagne galvanized. Foot insert in Vetrite.

Technical Features

Design Massimiliano Raggi

WEIGHT
70 KG

COM
11,6 ML

COL
16,2 SQM

PACKING
CARTON BOX + PALLET
W: 215 X D: 120 X H: 85 CM
W: 84 ^{5/8}" X D: 47 ^{1/4}" X H: 33 ^{1/2}"

GROSS WEIGHT
95 KG

VOLUME
2,2 CBM

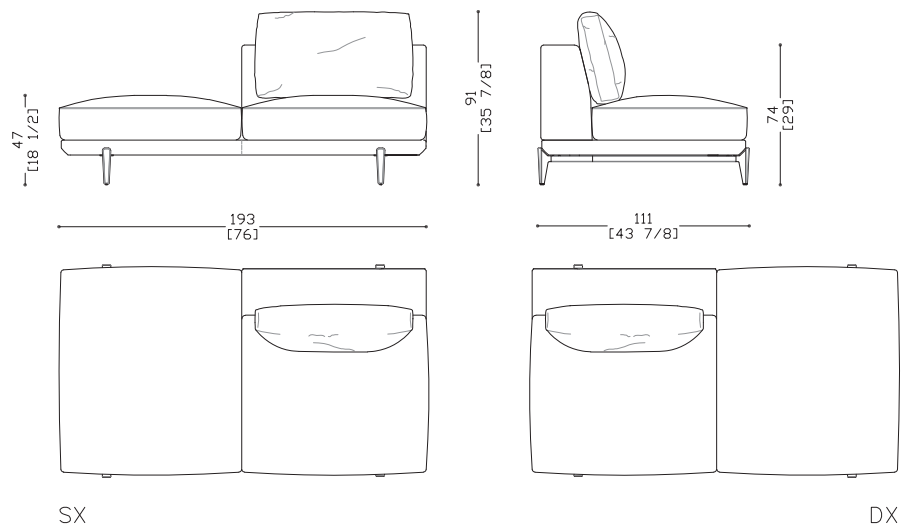

SOFA

Milton
MIC02 MIDDLE UNIT



Middle unit with structure in solid wood, plywood and polyurethane foam in various densities. Resinated and coupled with cotton. Seat cushions in polyurethane foam of various densities and feather mattress. Back cushions in down (67%) and ROLLOFILL (33%). Entirely removable in all its parts. Base frame in aluminum varnished in matte bronze nickel, matte champagne, or in glossy black nickel or glossy champagne galvanized. Foot insert in Vetríte.

Technical Features

Design Massimiliano Raggi

WEIGHT
70 KG

COM
11,6 ML

COL
16,2 SQM

PACKING
CARTON BOX + PALLET
W: 215X D: 120 X H: 85 CM
W: 84 ^{5/8}" X D: 47 ^{1/4}" X H: 33 ^{1/2}"

GROSS WEIGHT
95 KG

VOLUME
2,2 CBM

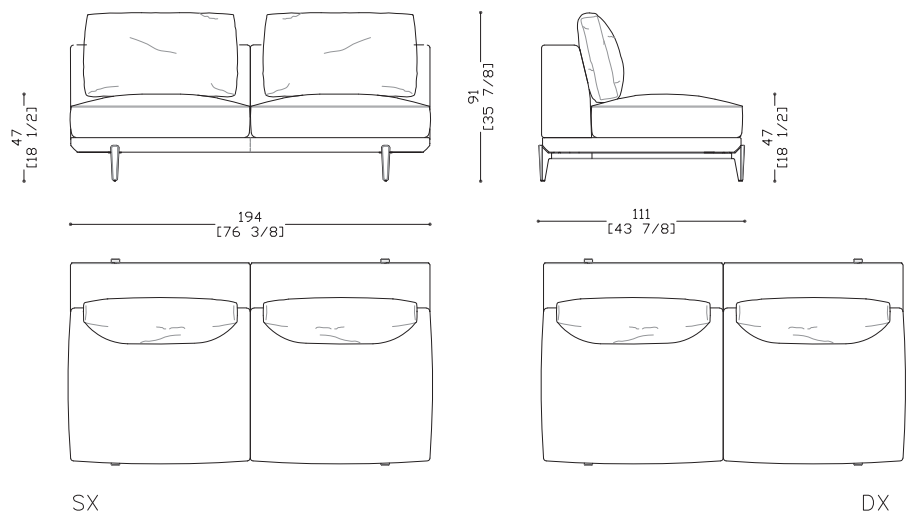

SOFA

Milton
MIP01 OTTOMAN



Pouf with structure in solid wood, plywood and polyurethane foam in various densities. Resinated and coupled with cotton.
Seat cushions in polyurethane foam of various densities and feather mattress. Entirely removable in all its parts.
Base frame in aluminum varnished in matte bronze nickel, matte champagne, or in glossy black nickel or glossy champagne galvanized. Foot insert in Vetríte.

Technical Features

Design Massimiliano Raggi

WEIGHT
30 KG

COM
4,1 ML

COL
5,7 SQM

PACKING
CARTON BOX + PALLET
W: 107 X D: 120 X H: 60 CM
W: 42 1/8" X D: 47 1/8" X H: 23 5/8"

GROSS WEIGHT
50 KG

VOLUME
0,6 CBM

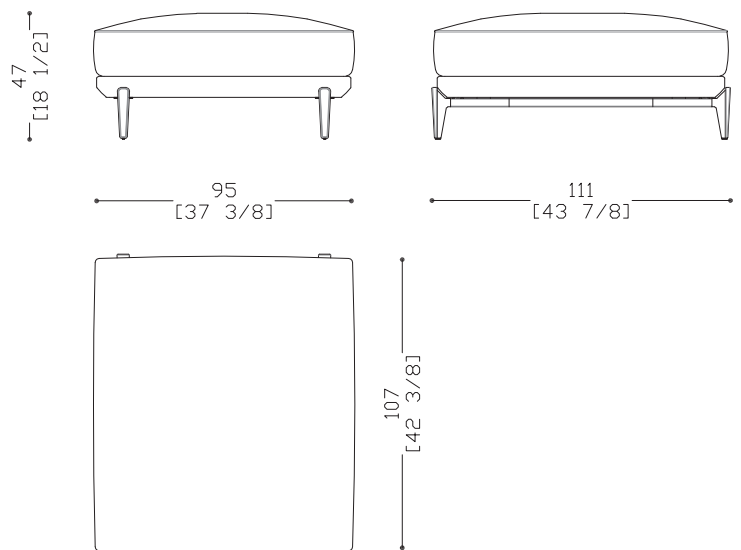

SOFA

Milton

MIT01SX SIDE UNIT LARGE OTTOMAN



Side unite large ottoman with structure in solid wood, plywood and polyurethane foam in various densities. Resinated and coupled with cotton. Seat cushions in polyurethane foam of various densities and feather mattress. Back cushions in down (67%) and ROLLOFILL (33%). Entirely removable in all its parts. Base frame in aluminum varnished in matte bronze nickel, matte champagne, or in glossy black nickel or glossy champagne galvanized. Foot insert in Vetricite. Optional on the armrest: side storage pocket in leather.

Technical Features

Design Massimiliano Raggi

WEIGHT
140 KG

COM
15,5 ML

COL
21,7 SQM

PACKING
CARTON BOX + PALLET
W: 320 X D: 120 X H: 85 CM
W: 126" X D: 43 7/8" X H: 35 7/8"

GROSS WEIGHT
150 KG

VOLUME
3,3 CBM

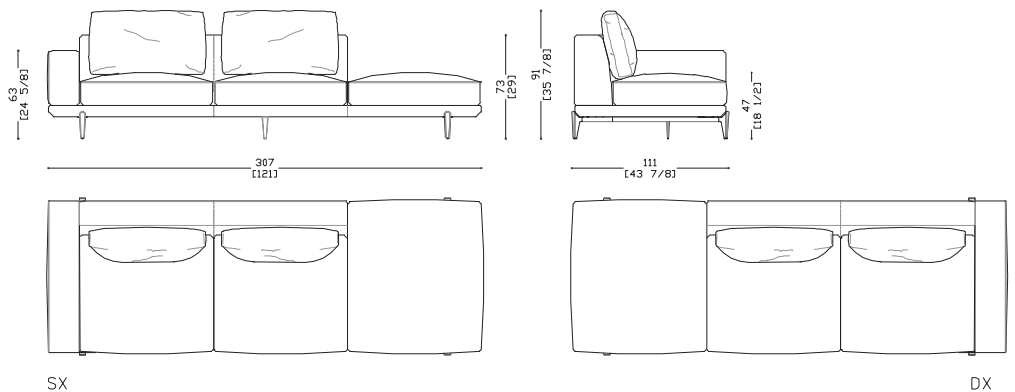

SOFA

Milton

MIT02 SX SIDE UNIT LARGE



Side unite large with structure in solid wood, plywood and polyurethane foam in various densities. Resinated and coupled with cotton. Seat cushions in polyurethane foam of various densities and feather mattress. Back cushions in down (67%) and ROLLOFILL (33%). Entirely removable in all its parts. Base frame in aluminum varnished in matte bronze nickel, matte champagne, or in glossy black nickel or glossy champagne galvanized. Foot insert in Vetrice. Optional on the armrest: side storage pocket in leather.

Technical Features

Design Massimiliano Raggi

WEIGHT
140 KG

COM
16,9 ML

COL
23,7 SQM

PACKING
CARTON BOX + PALLET
W: 320 X D: 120 X H: 85 CM
W: 126" X D: 43 7/8" X H: 35 7/8"

GROSS WEIGHT
150 KG

VOLUME
3,3 CBM

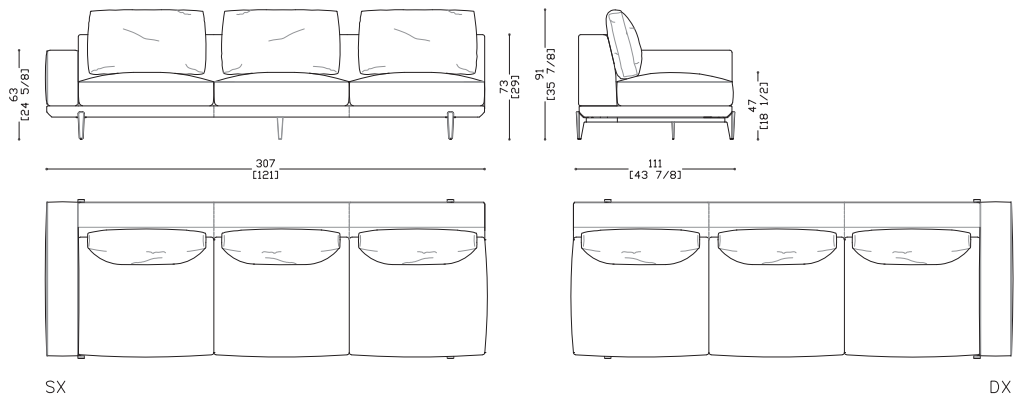

SOFA

Milton
MIT03 SX SIDE UNIT OTTOMAN



Side unite ottoman with structure in solid wood, plywood and polyurethane foam in various densities. Resinated and coupled with cotton. Seat cushions in polyurethane foam of various densities and feather mattress. Back cushion in down (67%) and ROLLOFILL (33%). Entirely removable in all its parts. Base frame in aluminum varnished in matte bronze nickel, matte champagne, or in glossy black nickel or glossy champagne galvanized. Foot insert in Vetrice. Optional on the armrest: side storage pocket in leather.

Technical Features

Design Massimiliano Raggi

WEIGHT
80 KG

COM
10,2 ML

COL
14,3 SQM

PACKING
CARTON BOX + PALLET
W: 225 X D: 120 X H: 85 CM
W: 51 1/8" X D: 68 7/8" X H: 33 1/2"

GROSS WEIGHT
100 KG

VOLUME
2,3 CBM

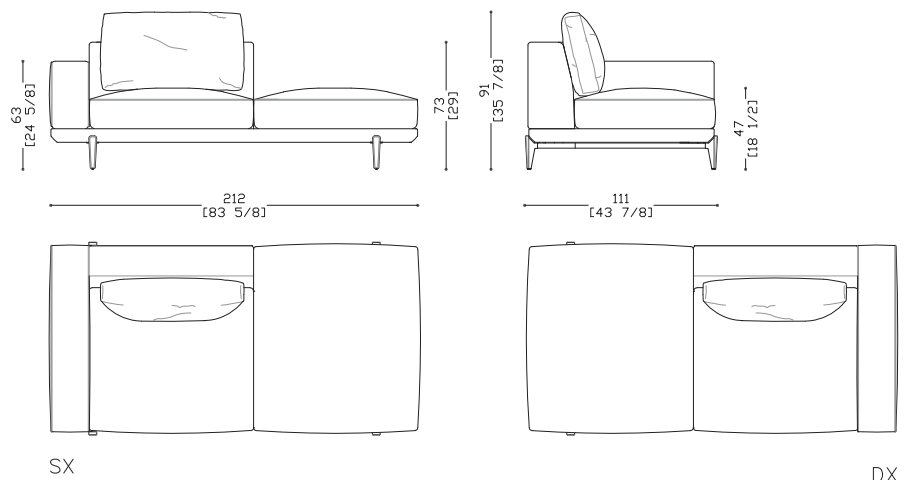

SOFA

Milton

MIT04 SX SIDE UNIT



Side unite with structure in solid wood, plywood and polyurethane foam in various densities. Resinated and coupled with cotton. Seat cushions in polyurethane foam of various densities and feather mattress. Back cushions in down (67%) and ROLLOFILL (33%). Entirely removable in all its parts. Base frame in aluminum varnished in matte bronze nickel, matte champagne, or in glossy black nickel or glossy champagne galvanized. Foot insert in Vetríte. Optional on the armrest: side storage pocket in leather.

Technical Features

Design Massimiliano Raggi

WEIGHT
90 KG

COM
13 ML

COL
18 SQM

PACKING
CARTON BOX + PALLET
W: 225 X D: 120 X H: 85 CM
W: 51 1/8" X D: 68 7/8" X H: 33 1/2"

GROSS WEIGHT
110 KG

VOLUME
2,3 CBM

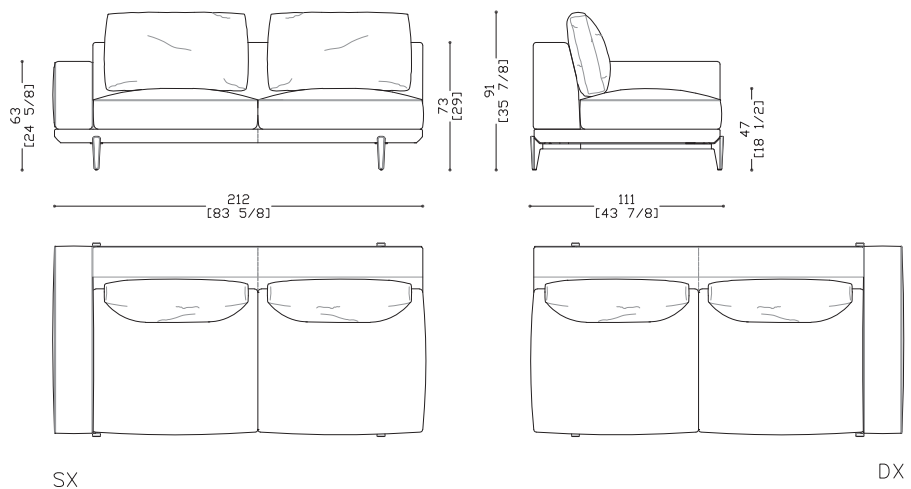

SOFA

Milton

MIT05 SX CHAISE LONGUE



Chaise longue with structure in solid wood, plywood and polyurethane foam in various densities. Resinated and coupled with cotton. Seat cushion in polyurethane foam of various densities and feather mattress. Back cushion in down (67%) and ROLLOFILL (33%). Entirely removable in all its parts. Base frame in aluminum varnished in matte bronze nickel, matte champagne, or in glossy black nickel or glossy champagne galvanized. Foot insert in Vetrite.
Optional on the armrest: side storage pocket in leather.

Technical Features

Design Massimiliano Raggi

WEIGHT
70 KG

COM
10,2 ML

COL
14,3 SQM

PACKING
CARTON BOX + PALLET
W: 130 X D: 175 X H: 85 CM
W: 51 ¹/₈" X D: 68 ⁷/₈" X H: 33 ¹/₂"

GROSS WEIGHT
90 KG

VOLUME
2 CBM

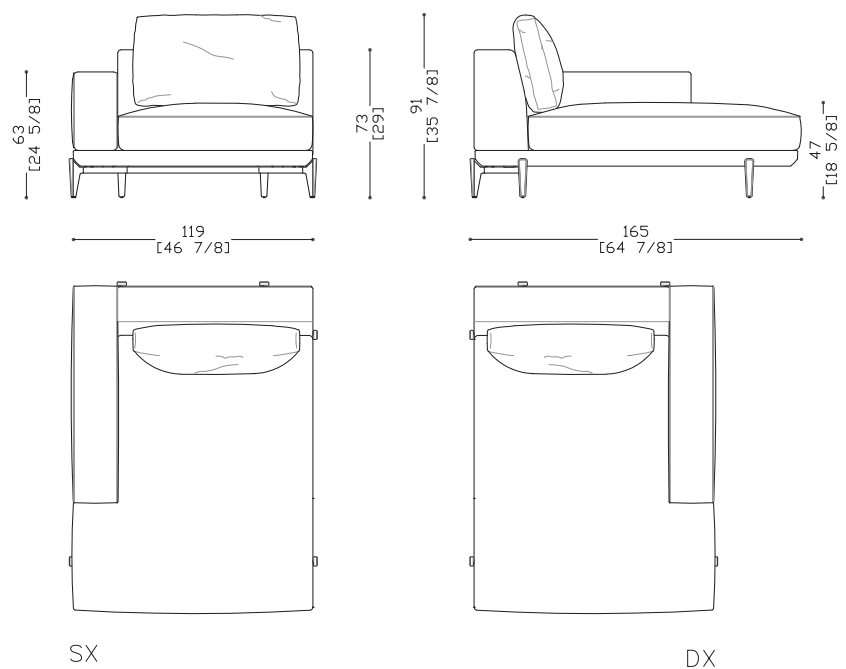

SOFA

Milton

OPTIONAL ARMREST



Optional on the armrest: side storage pocket in leather.

Technical Features

Design Massimiliano Raggi

